

# Home Automation using ZigBee Protocol

Pankaj Jadhav ,Amit Chaudhari , Swapnil Vavale

*Department of Computer Engineering  
University of Pune  
Pune-411007,India*

**Abstract** - Home automation is not new! Throughout history, we have continuously strived to automate tasks in the home in order to make our lives easier. Technology has now advanced to the point at which we wish to take an integrated approach to home automation, allowing appliances to communicate with each other and to be controlled in flexible ways. A wireless network approach to this communication and control provides an easy, cost-effective and scalable solution to home automation. The home automation systems provide mutual interoperability between various electronic, electrical, and power devices as well as interactive interface for people to control their operation. These features are very helpful to optimize and to economize energy consumption whereby saved energy during some few years could make more money than home automation systems implementation cost. These technologies make peoples' life also easier, especially for elderly persons and persons with disabilities. These systems exist of course, but there are many non-interoperable, expensive, and often wired systems. Wiring complicates implementation of the home automation in buildings which are already built, especially in historical ones.

**Index Terms** - Home Automation, ZigBee, Wireless Network, Embedded System, IEEE 802.15.

## I. INTRODUCTION

The major problem that leads me to develop such a project of smart home system is because of our humans' bad attitude itself. Lazy to turn OFF/ON home appliances are common problem among us. Percentage of wastage of high electricity is increasing year by year. A better smart home system is able to overcome such a serious problem. Older people are incapable to control home appliances by moving all over their house especially if double story house. Definitely they will suffer to control their home appliances if the control of the appliances are by switches. This kind of problem can be solved by developing a system which can control home appliances by a PC, because PC is becoming a product which is necessary to our daily life style nowadays. In future PC will be used by everyone, not only for communication purpose but also for other important purposes. There are many smart home system products present in the market. Most of them are not suitable and compatible to current lifestyle because of the use of old technology, complicated wired system, less task compliment and extra. Therefore in my project I'm using latest wireless technology which minimizes the complication of the connection and the product itself. By using PC as an input device, definitely the users feel easy to control their home appliances from any location and at any time.

## II. ZIGBEE IEEE802.15.4

ZigBee is a wireless technology developed by Zigbee Alliance as an open global standard to address the unique needs of low-cost, low-power, wireless sensor networks

[5].The standard takes full advantage of the IEEE 802.15.4 physical radio specification and operates in unlicensed bands worldwide at the following frequencies: 2.400–2.484 GHz, 902-928 MHz and 868.0–868.6 MHz The Zigbee used in this project is Xbee Zigbee Module from Digi International®. It can send data up to 30m and it has low power consumption (1mW for transmitting data). Xbee works in 2.4 GHz frequency and offers three modes of operation; AT mode, Application Programming Interface (API) mode and API with Escape (ESC) character mode. API operation is chosen to be used in this project due to several reasons. Firstly, it can transmit data to multiple destinations without having to enter the command mode. Secondly, it can identify the source address of each packet and thirdly, it will receive update on the transmission status whether it is successful or fail.

## III. METHODOLOGY

The methodology of this project design can be divided into two sections; hardware and software implementations. The hardware implementation consists of the development of the main controller, sensor nodes and the smart home sensor network while the software implementation focuses on the programming of the microcontroller using Embedded C.

### A. Hardware Implementation

Main controller is the most important part of the system in this project. Main controller will be the interface between the user and the system.89C51 microcontroller is used as the "brain" of the main controller. It has 32 general I/O port and the clock speed can be up to 24 MHz .This microcontroller is a CMOS technology IC which enable the low power consumptions. To access the main system, user must first key in the password. This password can be changed as desired.

### B. Software Implementation

The software part consists of programming 89C51 microcontroller using Embedded C using Keil µVision. The Graphical User Interface is designed by using Java.

## V. SYSTEM IMPLEMENTATION

This project offers an important feature of home automation. In home automation system, user can control their house by using the Graphical User Interface. Figure 1 shows the operation of the home automation system for the house. Figure 2 shows the Circuit Diagram of the system.

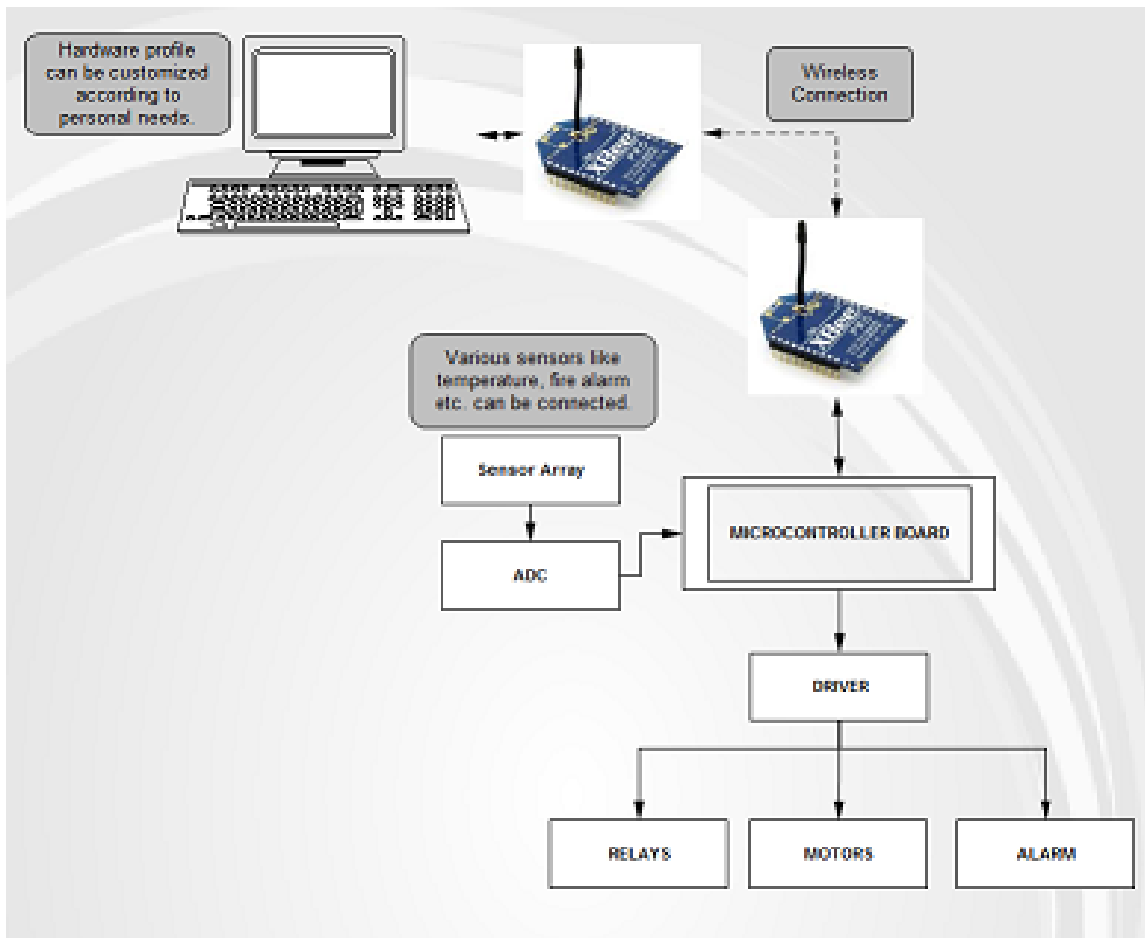

Fig 1.Home Automation System

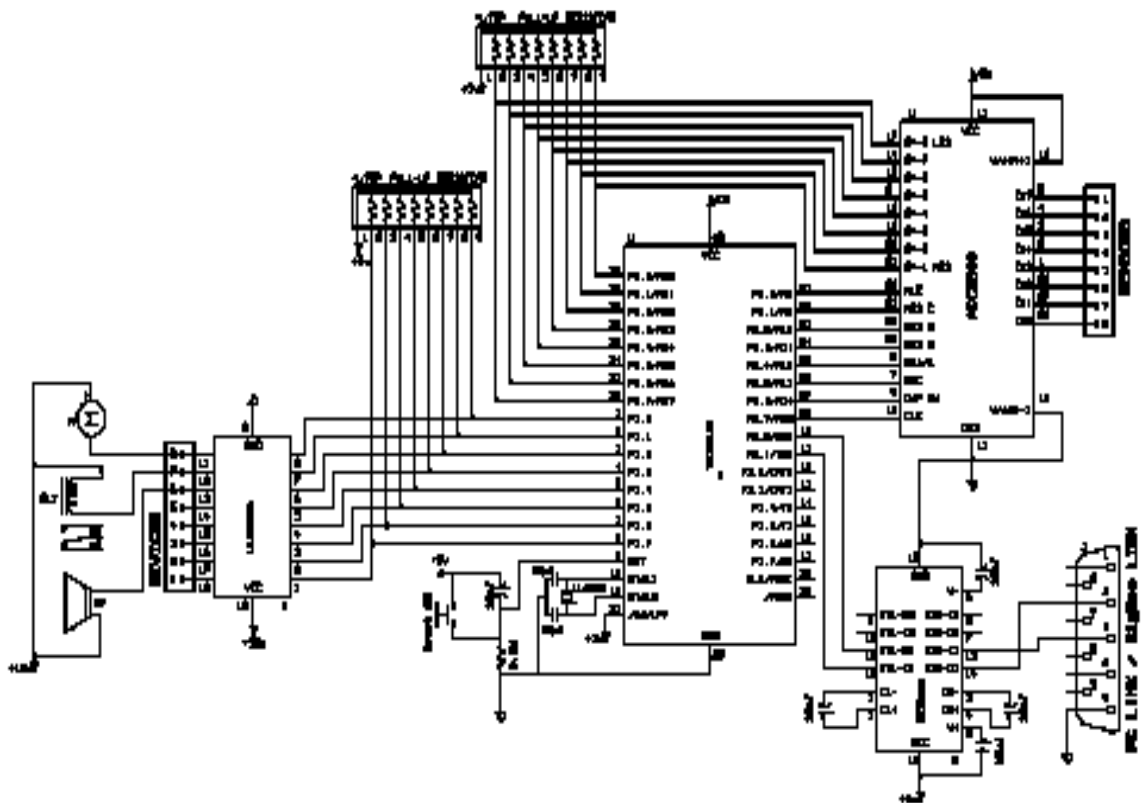

Fig 2.Circuit Diagram

## V. CONCLUSION

This paper describes ZigBee communication protocol and presents its potential deployment in smart home environment. Examples of prototype applications in home automation utilizing a ZigBee based wireless sensor network are illustrated. This system has attractive features such as SMS-Email notifications. In this perspective, ZigBee is emerging network technology as a wireless communication standard that is capable to satisfy such requirements. Moreover, its specification, which is based on IEEE 802.15.4 wireless protocols, promises complete interoperability.

## VI. ACKNOWLEDGEMENT

The authors would like to thank Mrs.Seema Bhardwaj for her help. This work was supported by the Oorjatech-The Interfacing Experts.

## REFERENCES

- [1] Chun-Liang Hsu, Teng-Yaw Hsu, Kuan-Yen Ho, and Wei-Bin Wu "Practical design of intelligent living-space based on Bluetooth System", *Maturitas*, vol. 64, issue 2, pp. 90-97, 2009.
- [2] Michal Varchola, Milos Drutarovsky, "Zigbee based home automation wireless sensor network" *IEEE PERCOM Workshops*, pp. 141-146, 2011.
- [3] Laur I., "Microcontroller based home automation system with security", *International Journal of Advanced Computer Science and Applications*, vol. 1, no. 6, pp. 60-65, 2010.
- [4] Gomez C., Paradells, J., "Wireless home automation networks: A survey of architectures and technologies", *IEEE Communications Magazine*, vol. 48, issue 6, pp. 92 – 101, 2010.
- [5] K.Balasubramanian and A. Cellatoglu, "Analysis of Remote Control Techniques Employed in Home Automation and Security Systems", *IEEE Magazine*, vol. 48, issue 6, pp. 92 – 101, 2011.
- [6] Javier Castro and James Psota, "The Specification, Design, and Implementation of a Home Automation System", *The American Journal of systems*, 2009.